

# Burrs

Hartmetallfrässtifte / Fraises limés / Fresas rotativas de metal duro

## Rim

Scheibenform  
Fraise disque  
Disco

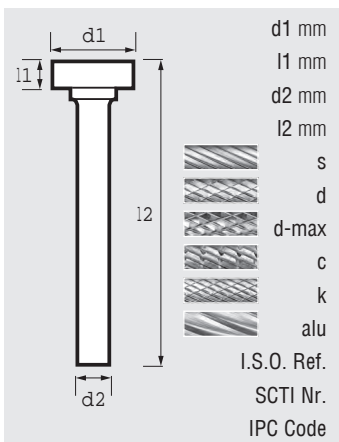
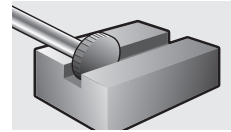

d1 mm	10	12	25	25
l1 mm	1.6	2.6	5.2	6.3
d2 mm	3	6	8	8
l2 mm	34	48	50	51
s	GT8240	GT8700	GT8100	GT9100
d	-	-	-	-
d-max	-	-	-	-
c	-	-	-	-
k	-	-	-	-
alu	-	-	-	-
I.S.O. Ref.	-	-	-	-
SCTI Nr.	-	-	-	-
IPC Code	49	25	25	25

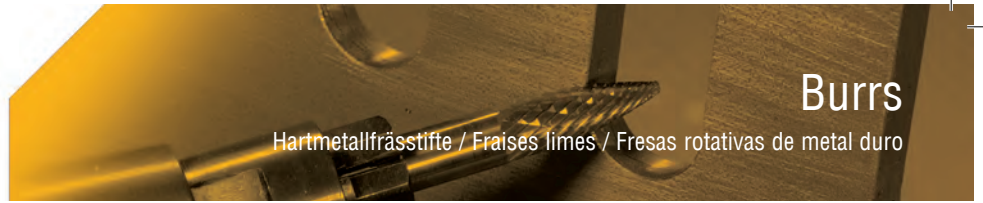

## RAPIDE® Coated burrs - Rim

**RAPIDE®** Scheibenform

**RAPIDE®** Fraise disque

**RAPIDE®** Disco

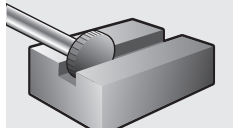

10
1.6
3
34
GCZ8240
-
-
-
-
-
-
-
-
-
22

12
2.6
6
48
GCZ8700
-
-
-
-
-
-
-
-
22

25
5.2
8
50
GCZ8100
-
-
-
-
-
-
-
-
22

25
6.3
8
51
GCZ9100
-
-
-
-
-
-
-
-
22

d1 mm  
l1 mm  
d2 mm  
l2 mm  
s- RAPIDE-D  
d- RAPIDE-D  
d-max RAPIDE-D  
c- RAPIDE-D  
k- RAPIDE-D  
alu- RAPIDE-A  
I.S.O. Ref.  
SCTI Nr.  
IPC Code

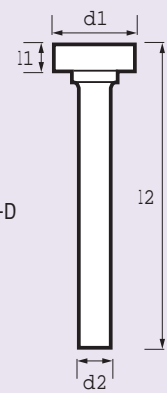

\* Additional lead times may apply on coated burrs.  
Längere Lieferzeiten dürfen mit beschichteten Hartmetallfrässtiften gefen.

\* Délais de livraison peuvent être plus longs pour les fraises limes revêtues.  
Las fresas recubiertas pueden tener un plazo de entrega más largo.